



TECHNICAL SUBMITTAL DATA SHEET

Plenum-Rated Water Leak Detection Kits

Job Name: _____

Job Location: _____

Engineer: _____

Engineer Approval: _____

Contractor: _____

Contractor Approval: _____

Contractor P.O.: _____

Representative: _____

MK6 SERIES

TYPICAL INSTALLATIONS INCLUDE:

- Plenum-mounted water heaters and water tanks (RS-094-MK6)
- Applications requiring valve installation up in the plenum, with power and leak detection sensing in the work space below (RS-080-MK6) – such as under break room sinks
- Simple water leak detection in a plenum space, including plenum HVAC/water chiller condensate pans for overflow detection (RS-096-MK6)

HIGHLY RECOMMENDED FOR:

- Commercial and municipal facilities
- Multi-residential complexes

KIT FEATURES:

- Plenum-rated wires for the water sensor, power supply and valve cable connections (as applicable)
- Step-down transformer (120, 208, 240 VAC to 24 VAC) with mounting plate in lieu of standard wall wart
- Pre-wired with basic connections to the power transformer and the sensor
- An audible alarm for quick identification of the problem
- All valves are suitable for potable water installations
- Dry contacts (NO/C/NC) to tie into existing building automation and security systems

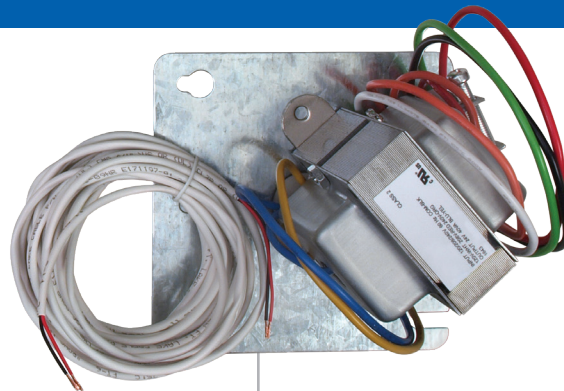

Plenum-Rated Wires,
Step-Down Transformer
& Wall Mounting Plate

APPLICATION CONSIDERATIONS:

In commercial buildings, water-fed appliances such as water tanks, chiller and water-supply lines are often located in plenum spaces. Because they are hidden from view, they are especially susceptible to the damage caused by an undetected water leak.

Local fire, safety and electrical codes have strict guidelines for installation of electrical devices in plenum spaces, typically requiring that all devices be hard-wired directly to their power source and that special-grade “plenum-rated” wires be used. These special requirements typically require a field retrofit to code, resulting in added time and expense.

RDT makes it easy and convenient to work within these challenging spaces with its plenum-rated FloodMaster MK6 series kits. These kits are also ideal for any application which requires hardwiring to a power source, such as for leak detection under sinks in break rooms.

MK6 SERIES TECHNICAL SUBMITTAL DATA SHEET

ORDERING INFORMATION:

RS-094-MK6 Water Heater/Tank Kits		
Valve Size	P/N	UPC
1/2"	RS-094-1/2-MK6	857640005960
3/4"	RS-094-3/4-MK6	857640005724
1"	RS-094-1-MK6	857640005977
1-1/4"	RS-094-1-1/4-MK6	857640005984
RS-080-MK6 Water Main Kits		
Valve Size	P/N	UPC
3/4"	RS-080-3/4-MK6	857640005861
1"	RS-080-1-MK6	857640005878
1-1/4"	RS-080-1-1/4-MK6	857640005885
1-1/2"	RS-080-1-1/2-MK6	857640005892
2"	RS-080-2-MK6	857640005908
2-1/2"	RS-080-2-1/2-MK6	857640005915
3"	RS-080-3-MK6	857640005922
4"	RS-080-4-MK6	857640005939
RS-096-MK6 Water Alarm Kits		
Valve Size	P/N	UPC
N/A	RS-096-MK6	857640005946

PLENUM-RATED COMPONENT SPECIFICATIONS:

Step-Down Transformer

Voltage 120, 208 or 240V AC
to 24V AC

Transformer Cable..... 12'

PLENUM-RATED COMPONENT DIMENSIONS:

Step-Down Transformer

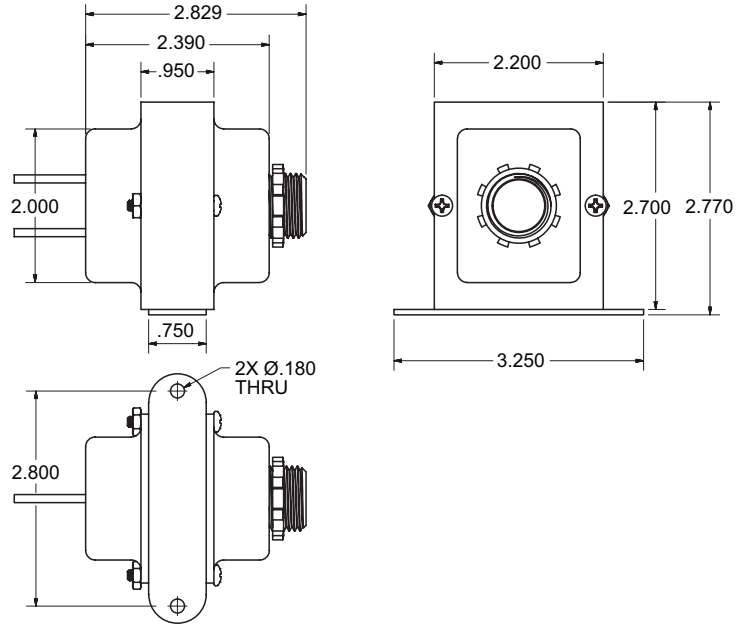

Mounting Plate

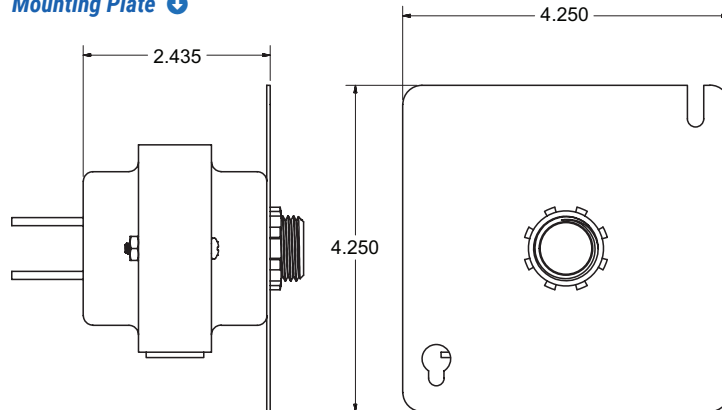

RDT recommends that installations be completed by a licensed plumber to ensure that all local code requirements are followed.



Reliance Detection Technologies, LLC
27 Business Park Drive
Branford, CT 06405

203-488-2684 or 888-771-4929
info@RelianceDetection.com
www.Reliandetection.com