

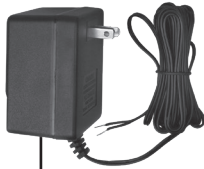

RS-092

- BY -

RDT
RELIANCE
DETECTION TECHNOLOGIES



MK1 Wall Wart

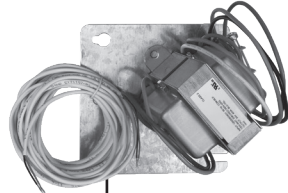

MK2 Step-Down
Transformer

Hose-Fed Appliance Leak Detection & Automatic Shut-Off System

Congratulations on your purchase of a FloodMaster RS-092 hose-fed appliance leak detection system from Reliance Detection Technologies. This product is designed to automatically shut off the water supply to the appliance if a leak is detected. It is available with either a standard wall wart (RS-092-MK1) or step-down transformer (RS-092-MK2) to power the unit.

To ensure proper installation and to maximize the performance of your RS-092 water leak detection system, please read this manual thoroughly before installing or operating the system.

NOTE: This installation and operating manual contains important information about the operation of the RS-092 system. If this system is being installed for use by a different user, please be sure a copy of this manual is left with the system for future reference.



Warning: For use with water only. Do not install on gas line. Never install this device on a fire protection or fire suppression system. For indoor use only.

www.RelianceDetection.com

Toll-Free: 888-771-4929

RS-092 System Components (included in kit):

- | | |
|---|--|
| 1 – Receiver box / actuator | 1 – 10' rope sensor with 6' lead wire |
| 1 – 1/2" full port lead-free shut-off valve (NSF/ANSI 61 and 372) | 1 – 120V AC wall wart with 12' lead wire (MK1) |
| 2 – 3/8" x 1/2" compression fittings (male and female) | 1 – 120, 208 or 240V AC to 24V AC step-down transformer with wall mounting plate (MK2) |

NOTE: The RS-092 can be used on existing or new appliance installations. RDT recommends that install be completed by a licensed plumber/electrician to ensure that all local code requirements are followed.

INSTALLATION INSTRUCTIONS

1. Turn off the water supply feed line to the appliance.
2. Prior to installation, manually exercise the valve body to fully closed and back to fully open position by holding it in your hand, applying a pliers to the valve stem and turning. Thread the valve body into the feed water line after the manual shut-off. Apply pipe sealant or Teflon® tape to the NPT threads and tighten.
3. Install the valve body with fittings in the desired location. Mount the compression fitting on the supply pipe and then mount the hose line compression fitting to the male fitting.
4. The receiver connector comes prewired with basic connections to the power supply and the sensor. Using an appropriate screwdriver, make any additional electrical connections as may be desired for output contacts or additional sensors per wiring Figure 1. (*Note: additional sensors can be connected to either 6 & 7 or 8 & 9, as wiring space allows.*) Then snap the terminal wiring block into the receiver housing at the mating slot provided.
5. Secure the valve body in one hand and snap the receiver into place on the valve body mounting pad. (*Note: Improper alignment of the valve stem may interfere with proper receiver mounting. If any resistance is encountered, confirm the witness mark on the valve stem is in alignment with the valve ports. Use an appropriate hand tool, such as pliers, to clamp down on the valve stem and turn in the appropriate direction until the desired position is achieved.*)
6. Place the rope sensor where water from a leak is most likely to first accumulate (under the dishwasher, around the water filtration system, in a catch pan, etc.).
7. For RS-092-MK1 Kit – Plug the wall wart into a 120V AC wall outlet. The green “Power” indicator light on the receiver will turn on. Proceed to Step 9.
8. For RS-092-MK2 Kit – Turn off the main power. Wire the blue and yellow wires (24V AC output) to the plenum wire that is prewired to the power input of the receiver contact plug. Wire the appropriate inputs to the main power source – refer to TRANSFORMER WIRING and TRANSFORMER MOUNTING INSTRUCTIONS for more details. Turn on the power. The green “Power” indicator light on the receiver will turn on.
9. **Function Test the system as follows:**
 - Apply a wet 4” section of paper towel to the wire rope sensor. The audible alarm will sound and the valve will rotate to the closed position.
 - The red “Valve Closed” LED will turn on when the valve is completely closed (approximately 45-second cycle time). Confirm that there is no water flow to the appliance.
 - Remove the wet paper towel, dry the wire rope sensor and place it in the desired location.
 - Press and release the “Reset” button on the receiver to open the valve and begin the flow of water again (approximately 45 seconds to fully re-open). The green “Power” indicator light will flash once to indicate the reset process has begun. Confirm that water is flowing to the appliance.

TRANSFORMER WIRING INSTRUCTIONS

The supplied transformer has multiple input taps to accommodate different line voltages. If the existing line voltage you have at your facility is:

120V AC – The **WHITE** wire from the transformer should be connected to the hot leg of the input voltage and the black wire to the neutral leg.

208V AC – The **RED** wire from the transformer should be connected to the hot leg of the input voltage and the black wire to the neutral leg.

240V AC – The **ORG** wire from the transformer should be connected to the hot leg of the input voltage and the black wire to the neutral leg.

The **GREEN** wire in all cases must be connected to **EARTH GROUND**.

Each wiring combination as stated above yields the same 24V AC output across the **BLUE** and **YELLOW** wires of the secondary winding of the transformer. **See back for Transformer Mounting Instructions.**

RS-092 HOSE-FED APPLIANCE KIT

1. Receiver box
2. Valve Closed LED
3. Power LED
4. Wiring terminal block
5. Reset button
6. Valve actuator
7. Shut-off valve
8. Male compression fitting
9. Female compression fitting
10. Rope sensor
11. Sensor lead wire
12. MK1 wall wart
13. MK2 step-down transformer
14. MK2 mounting plate

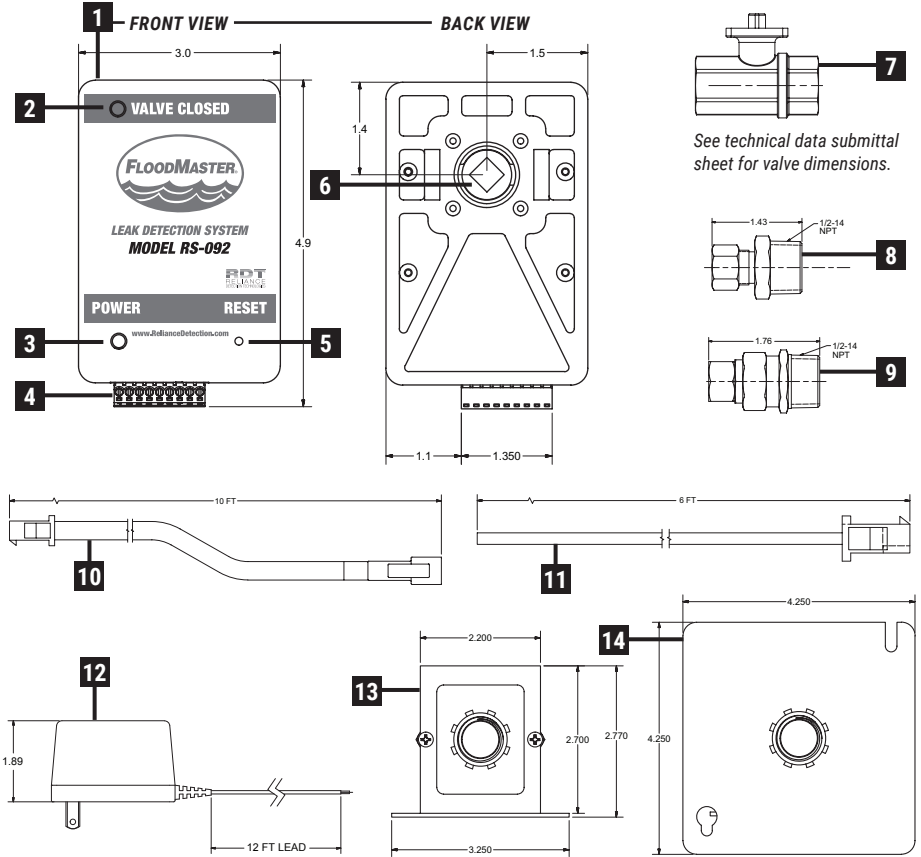

**FIGURE 1 –
WIRING DIAGRAM
(RS-092-MK2 SHOWN)**

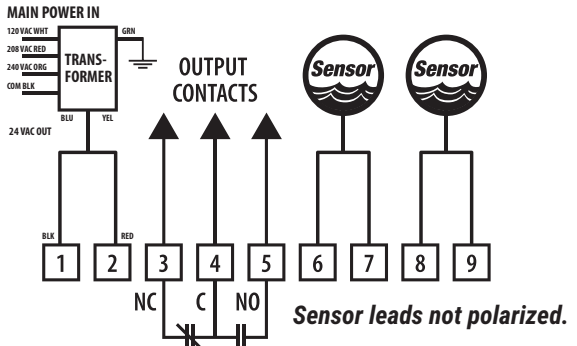

TRANSFORMER MOUNTING INSTRUCTIONS

The kit contains a cover plate for a standard junction box. The cover has a hole or knock out in the center. It is designed such that the transformer can be mounted to it and then screwed into the junction box.

1. To mount the transformer to the cover, carefully route its primary wires through the hole in the cover.
2. Tilt the cover so that the head of the retaining screw on the transformer is over the cover.
3. Back the screw out until the cover slips under the threaded end of the retaining screw.
4. Tighten the screw until the transformer is secured on the cover. The threaded end of the screw is designed to press against the cover to hold the transformer in place.

OUTPUT SIGNAL CONNECTIONS

The unit also provides output signal capabilities (SPDT Relay Output Contact) for connection to a home security panel or for use with an appropriate relay to control a secondary device, such as a pump. See Figure 1 for wiring diagram.

Normally Closed Circuit – Terminal Pins 3 & 4

Normally Open Circuit – Terminal Pins 4 & 5

OPERATION & SYSTEM RESET

In the event the system activates, locate the source of the leak, remove the sensor from the water and dry. A hair dryer may be used to expedite the drying time. Correct the problem causing the leak and replace the sensor in the desired leak detection location. Press and release the “Reset” button on the receiver to open the valve and begin the flow of water again. The green “Power” indicator light on the receiver will flash once to confirm the reset.

MAINTENANCE

Test the system annually per the function test (install step 9) to ensure correct operation and maintain product warranty status. At a minimum, exercise (press and release) the “Reset” button on the receiver annually.

EMERGENCY MANUAL VALVE OPERATION

The unit is equipped with an emergency feature for the manual rotation of the valve. Disengage the actuator from the valve and manually changing the valve to open or closed as follows:

1. Turn off the main power to the transformer.
2. Stabilize the water feed line by grabbing it in one hand near the valve. While grasping the actuator housing in the other hand, pull the actuator housing away from the water feed line.
3. Using an appropriate hand tool (such as a pliers), clamp down on valve stem and turn in the appropriate direction until the desired position is achieved. Note the top of the stem is slotted to indicate valve position (in line with water flow would indicate open valve; slot across water line would indicate closed valve).
4. Before remounting the actuator, return the valve to the original position prior to the manual rotation.
5. Remount the actuator and restore the main power to the transformer.
6. Test for correct operation per the function test listed in install step 9.

NEED INSTALLATION OR SETUP ASSISTANCE?

Call toll-free: 888-771-4929 or visit www.RelianceDetection.com/support/RS-092



203-488-2684 or 888-771-4929

27 Business Park Drive, Branford, CT 06405

www.RelianceDetection.com info@RelianceDetection.com

All specifications subject to change without notice.

© Copyright 2020 Reliance Detection Technologies, LLC – A Madison Company

ECN # 11386, 09/2020, MF158, RevB